

General Description

The Sanrise SRC60R090B is a high voltage power MOSFET, fabricated using advanced super junction technology. The resulting device has extremely low on resistance, low gate charge and fast switching time, making it especially suitable for applications which require superior power density and outstanding efficiency.

The SRC60R090B break down voltage is 600V and it has a high rugged avalanche characteristics. The SRC60R090B is available in TO-220F and TO-247 packages.

Features

- Ultra Low $R_{DS(ON)} = 90m\Omega @ V_{GS} = 10V$.
- Ultra Low Gate Charge, $Q_g=90.3nC$ typ.
- Intrinsic Fast-Recovery Body Diode
- Fast switching capability
- Robust design with better EAS performance

Application

- AC/DC Power Supply
- EV Charger
- PC / Sever / Telecom

Symbol

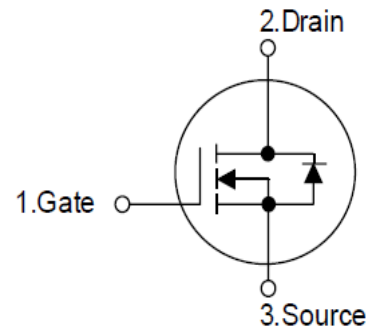

Figure 1 Symbol of SRC60R090B

Package Type

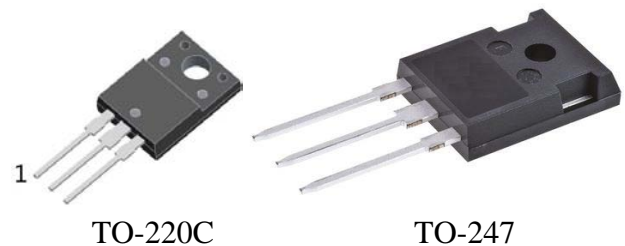
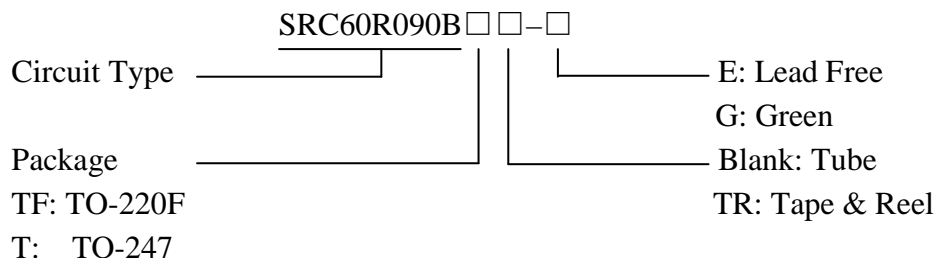

Figure 2 Package Types of SRC60R090B

Ordering Information



Package	Part Number		Marking ID		Packing Type
	Lead Free	Green	Lead Free	Green	
TO-220F	SRC60R090BTF-E	SRC60R090BTF-G	SRC60R090BTFE	SRC60R090BTFG	Tube
TO-247	SRC60R090BT-E	SRC60R090BT-G	SRC60R090BTE	SRC60R090BTG	Tube

Absolute Maximum Ratings

Parameter	Symbol	Rating	Unit
Drain-Source Voltage	V_{DSS}	600	V
Gate-Source Voltage	V_{GSS}	±30	V
Continuous Drain Current	I_D	$T_C=25^{\circ}C$	39.5
		$T_C=125^{\circ}C$	17.8
Pulsed Drain Current (Note 2)	I_{DM}	118.5	A
Avalanche Energy, Single Pulse (Note 3)	E_{AS}	550	mJ
Avalanche Energy, Repetitive (Note 2)	E_{AR}	0.6	mJ
Avalanche Current, Repetitive (Note 2)	I_{AR}	4.5	A
Continuous Diode Forward Current	I_S	39.5	A
Diode Pulse Current	$I_{S,PULSE}$	118.5	A
MOSFET dv/dt Ruggedness, $V_{DS} \leq 480V$	dv/dt	50	V/ns
Reverse Diode dv/dt, $V_{DS} \leq 480V$, $I_{SD} \leq I_D$	dv/dt	50	V/ns
Operating Junction Temperature	T_J	150	°C
Storage Temperature	T_{STG}	-55 to 150	°C
Lead Temperature (Soldering, 10 sec)	T_{LEAD}	260	°C

Note:

- Absolute maximum ratings are those values beyond which the device could be permanently damaged. Absolute maximum ratings are stress ratings only and functional device operation is not implied.
- Repetitive Rating: Pulse width limited by maximum junction temperature
- $I_{AS} = 4.5A$, $V_{DD} = 60V$, $R_G = 25\Omega$, Starting $T_J = 25^{\circ}C$

Electrical Characteristics
 $T_J = 25^{\circ}\text{C}$, unless otherwise specified.

Parameter	Symbol	Test Conditions	Min	Typ	Max	Unit
Statistic Characteristics						
Drain-Source Breakdown Voltage	BV_{DSS}	$V_{GS}=0V, I_D=250\mu A$	600			V
Zero Gate Voltage Drain Current	I_{DSS}	$V_{DS}=600V, V_{GS}=0V$			10	μA
Gate-Body Leakage Current	Forward	$I_{GSSF}, V_{GS}=30V, V_{DS}=0V$			100	nA
	Reverse	$I_{GSSR}, V_{GS}=-30V, V_{DS}=0V$			-100	nA
Gate Threshold Voltage	$V_{GS(TH)}$	$V_{DS}=V_{GS}, I_D=800\mu A$	3.5	4.0	4.5	V
Static Drain-Source On-Resistance	$R_{DS(ON)}$	$V_{GS}=10V, I_D=20A$		78	90	$m\Omega$
Gate Resistance	R_G	$f=1MHz, \text{Open Drain}$		0.7		Ω
Dynamic Characteristics						
Input Capacitance	C_{ISS}	$V_{DS}=50V, V_{GS}=0V, f=1MHz$		3300		pF
Output Capacitance	C_{OSS}			136		
Reverse Transfer Capacitance	C_{RSS}			2.3		
Effective output capacitance, energy related ^{NOTE5}	$C_{O(er)}$	$V_{GS}=0V, V_{DS}=0\dots 400V$		98.2		pF
Effective output capacitance, time related ^{NOTE6}	$C_{O(tr)}$			601		
Turn-on Delay Time	$t_{d(on)}$	$V_{DD}=400V, I_D=20A, R_G=1.8\Omega, V_{GS}=10V$		24		ns
Rise Time	t_r			38		
Turn-off Delay Time	$t_{d(off)}$			48		
Fall Time	t_f			10		
Gate Charge Characteristics						
Gate to Source Charge	Q_{gs}	$V_{DD}=480V, I_D=20A, V_{GS}=0 \text{ to } 10V$		22.9		nC
Gate to Drain Charge	Q_{gd}			45.6		
Gate Charge Total	Q_g			90.3		
Gate Plateau Voltage	$V_{plateau}$			6.5		V
Reverse Diode Characteristics						
Drain-Source Diode Forward Voltage	V_{SD}	$V_{GS}=0V, I_{SD}=20A$		0.9	1.1	V
Reverse Recovery Time	t_{rr}	$V_R=100V, I_F=20A, dI_F/dt=100A/\mu s$		158		ns
Reverse Recovery Charge	Q_{rr}			0.95		μC
Peak Reverse Recovery Current	I_{rrm}			12		A

Note:

 5. $C_{O(er)}$ is a fixed capacitance that gives the same stored energy as C_{OSS} while V_{DS} is rising from 0 to 480V

 6. $C_{O(tr)}$ is a fixed capacitance that gives the same charging time as C_{OSS} while V_{DS} is rising from 0 to 480 V

Typical Performance Characteristics

Figure 7: Typ. Output Characteristics

 $I_D = f(V_{DS}); T_j = 25^\circ\text{C}; \text{parameter: } V_{GS}$
Figure 8: Typ. Output Characteristics

 $I_D = f(V_{DS}); T_j = 125^\circ\text{C}; \text{parameter: } V_{GS}$
Figure 9: Typ. Drain-Source On-State Resistance

 $R_{DS(ON)} = f(I_D); T_j = 125^\circ\text{C}; \text{parameter: } V_{GS}$
Figure 10: Typ. Drain-Source On-State Resistance

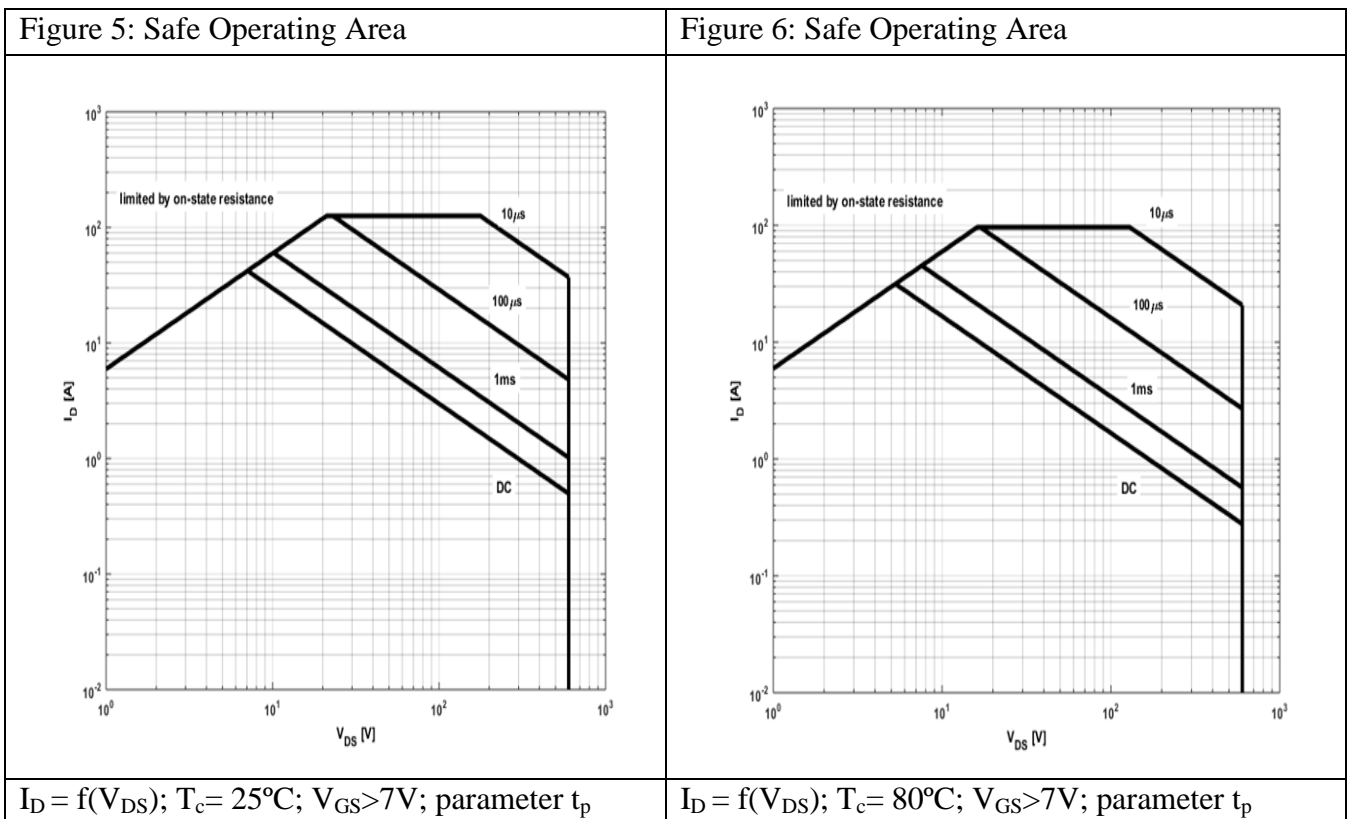
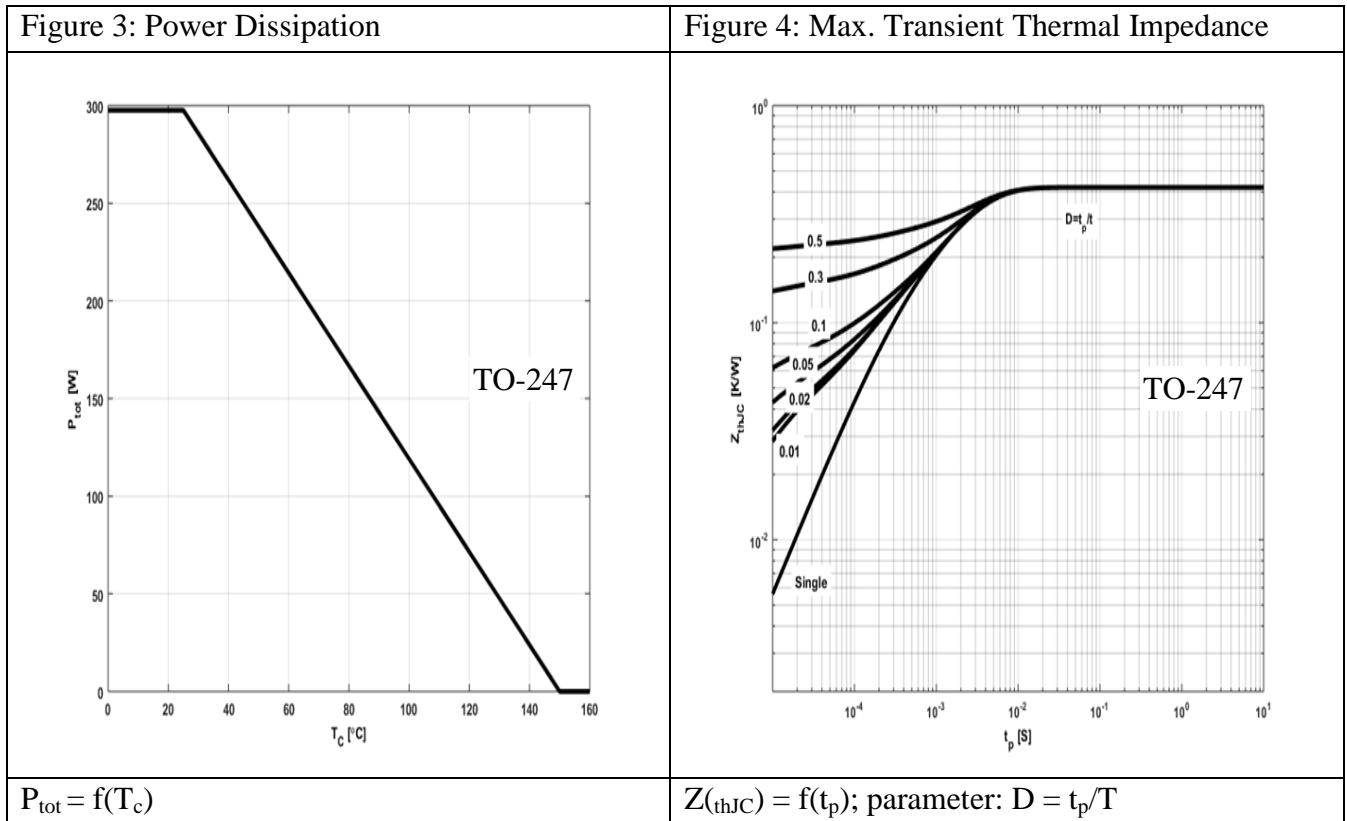
 $R_{DS(ON)} = f(T_j); I_D = 20\text{A}; V_{GS} = 10\text{V}$

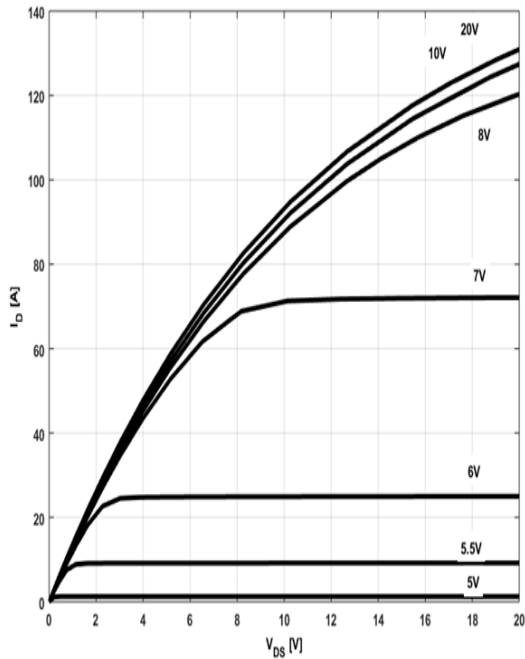
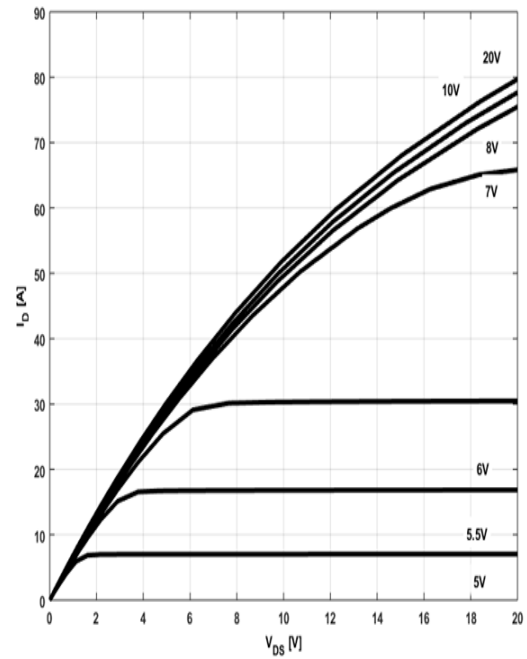
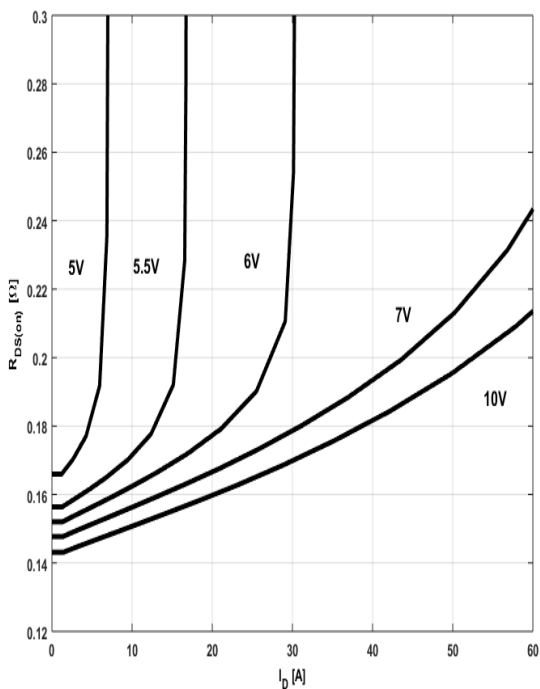
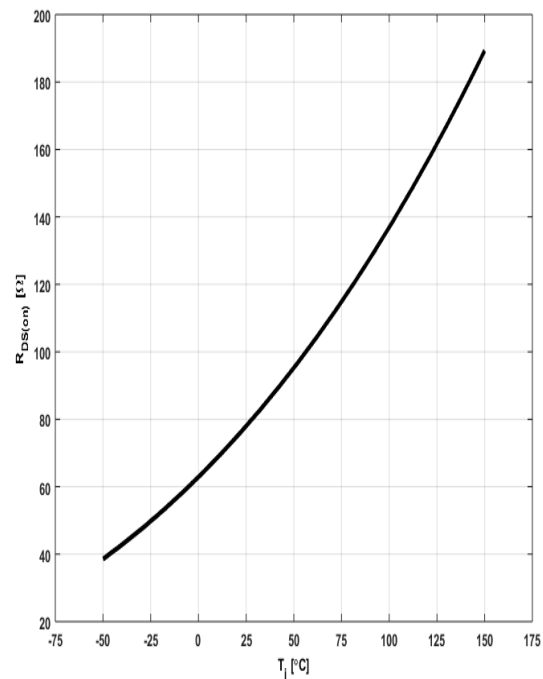
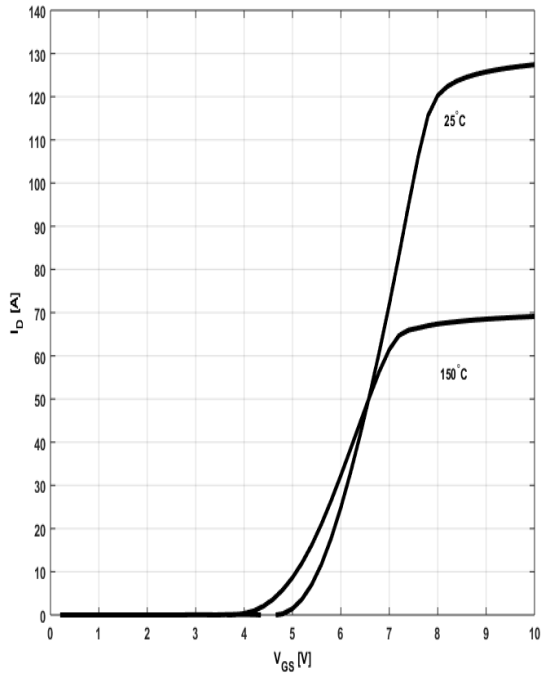
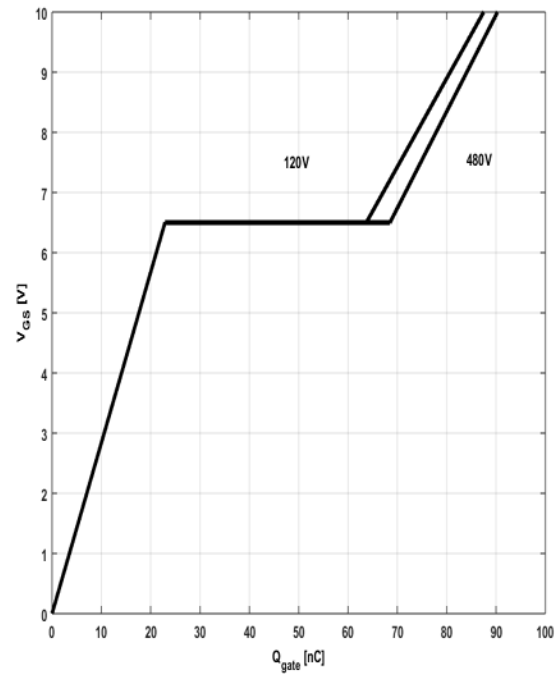
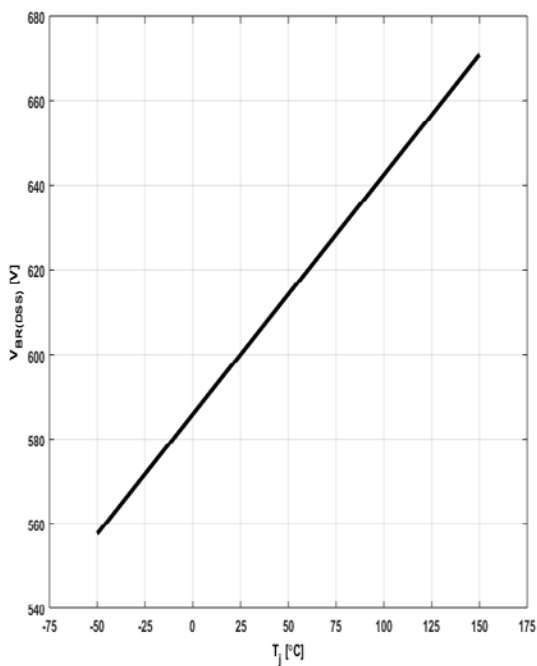
Figure 11: Typ. Transfer Characteristics

$$I_D = f(V_{GS}); V_{DS} = 20V$$

Figure 12: Typ. Gate Charge

$$V_{GS} = f(Q_{gate}), I_D = 20A \text{ pulsed}$$

Figure 13: Drain-Source Breakdown Voltage

$$V_{BR(DSS)} = f(T_j); I_D = 1mA$$

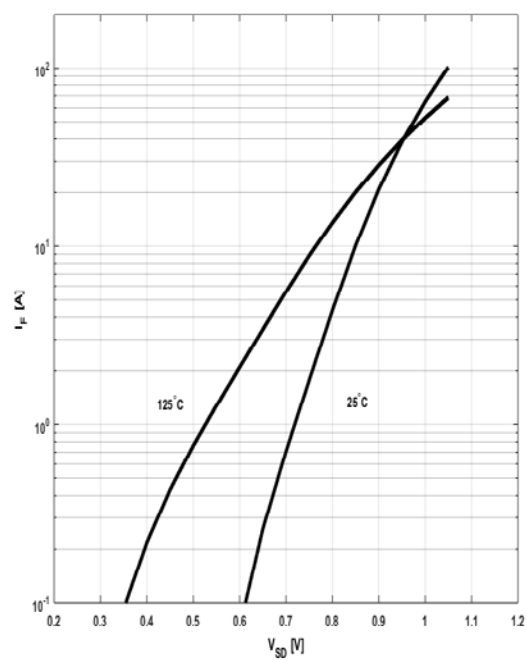
Figure 14: Forward Characteristics of Reverse Diode

$$I_F = f(V_{SD}); \text{parameter: } T_j$$

Figure 15: Avalanche Energy

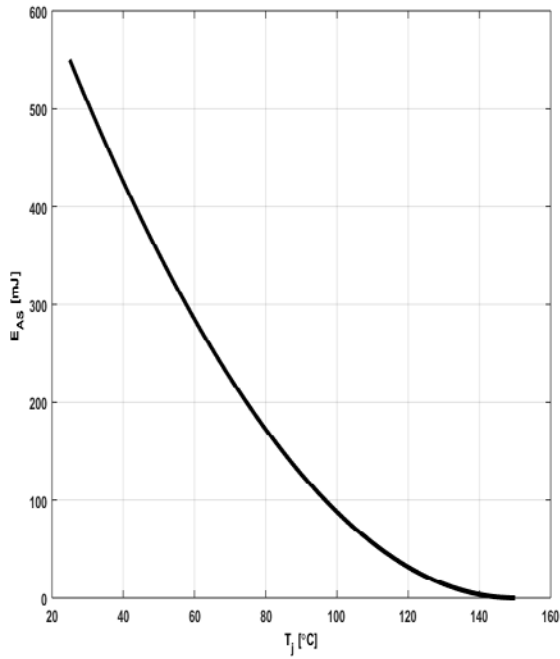

$E_{AS}=f(T_j)$; $I_D=4.5A$; $V_{DD}=60V$

Figure 16: Typ. Capacitances

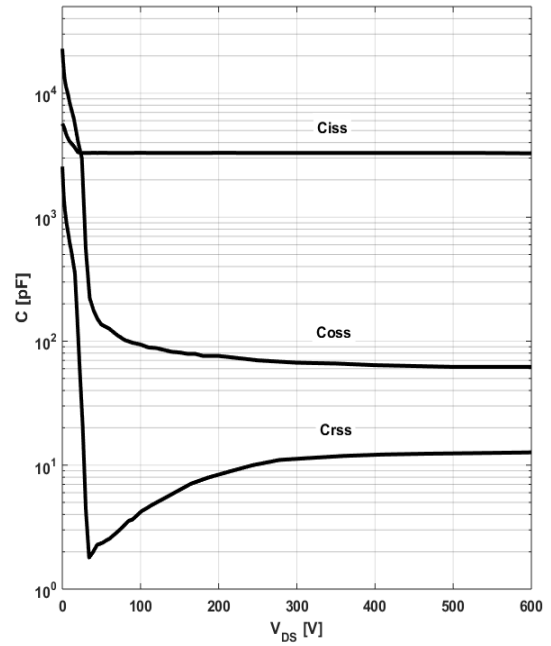

$C=f(V_{DS})$; $V_{GS}=0$; $f=1MHz$

Figure 17: C_{OSS} Stored Energy

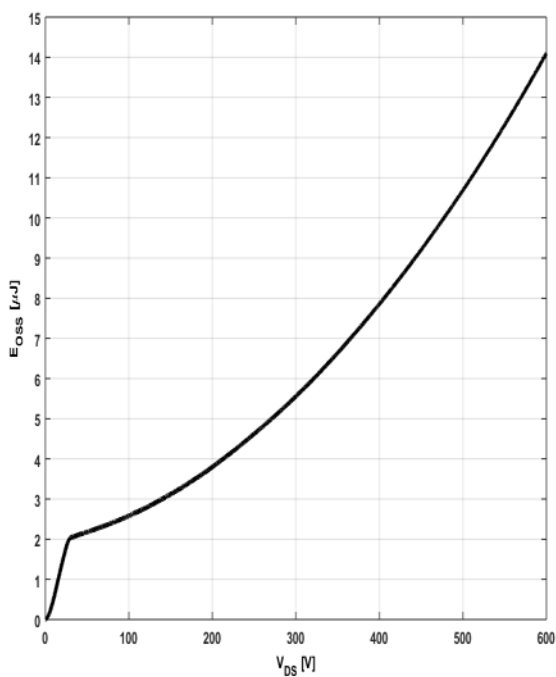

$E_{OSS}=f(V_{DS})$

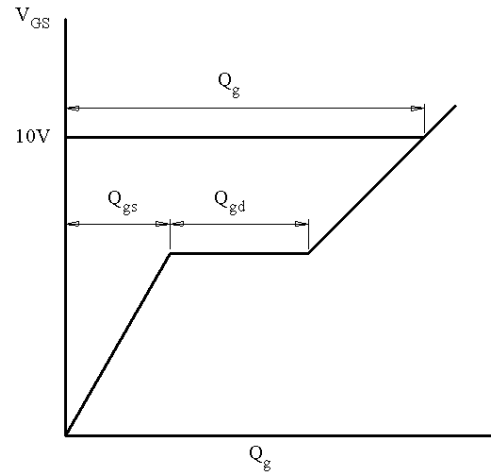
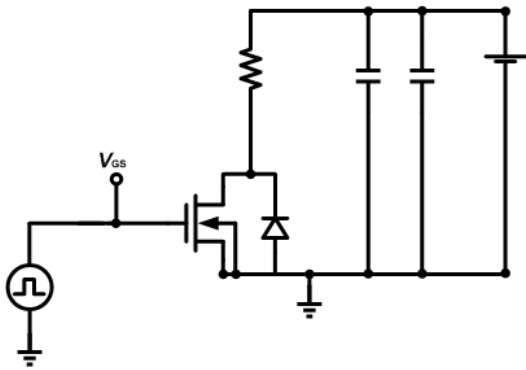
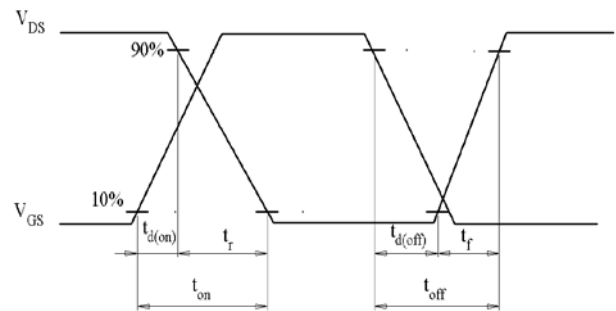
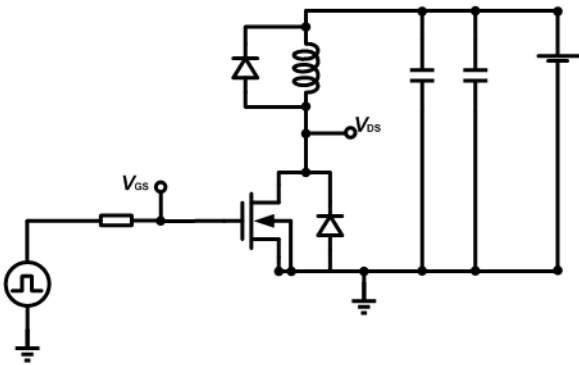
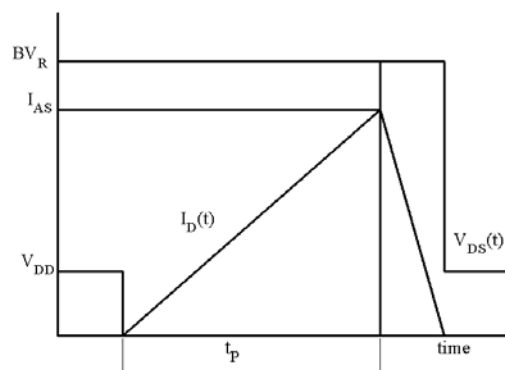
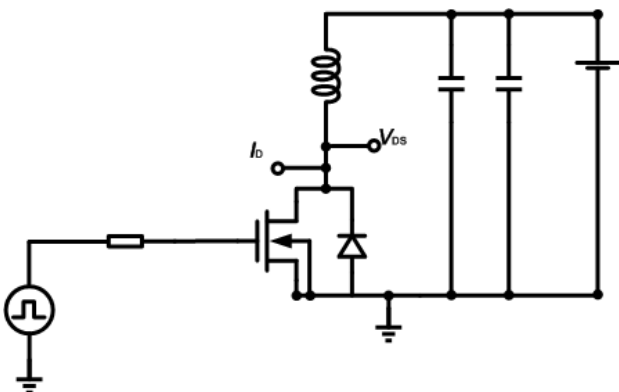
Test Circuits
1. Gate Charge Test Circuit & Waveform

2. Switch Time Test Circuit

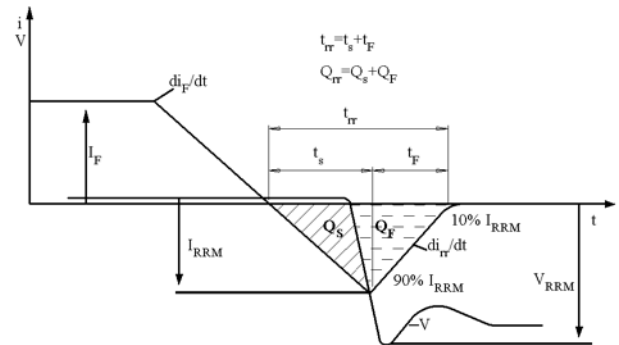
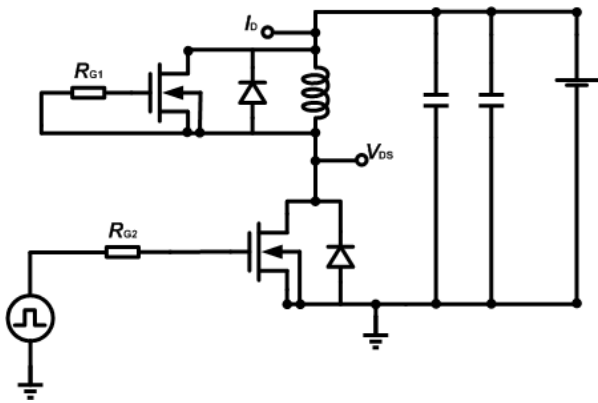
3. Unclaimed Inductive Switching Test Circuit & Waveforms

4. Test Circuit and Waveform for Diode Characteristics

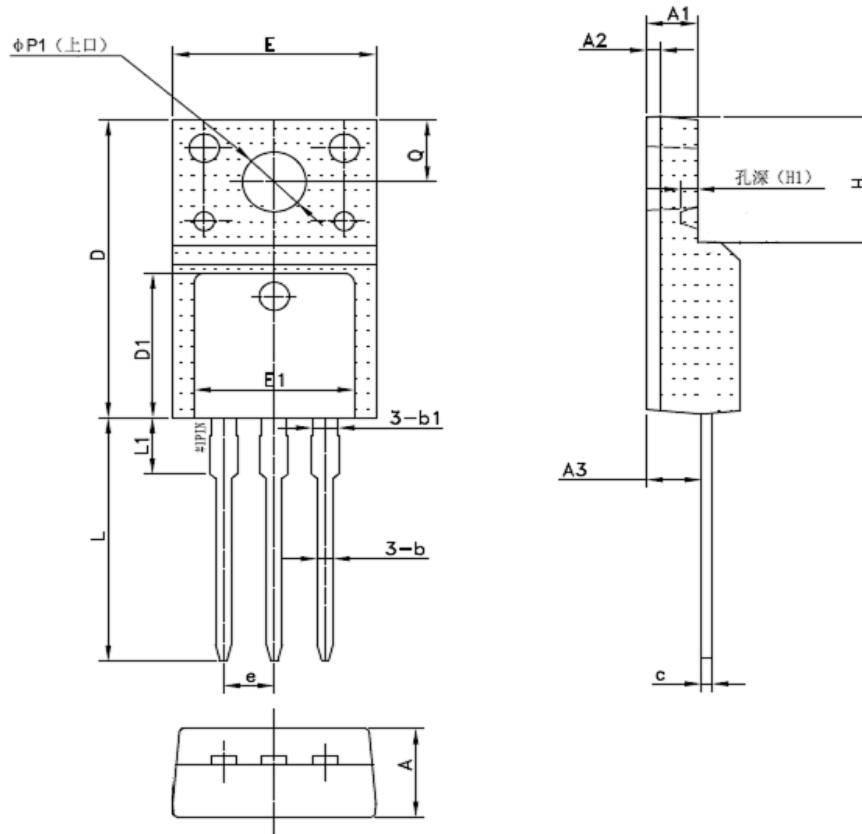

Mechanical Dimensions
TO-220F

Unit: mm

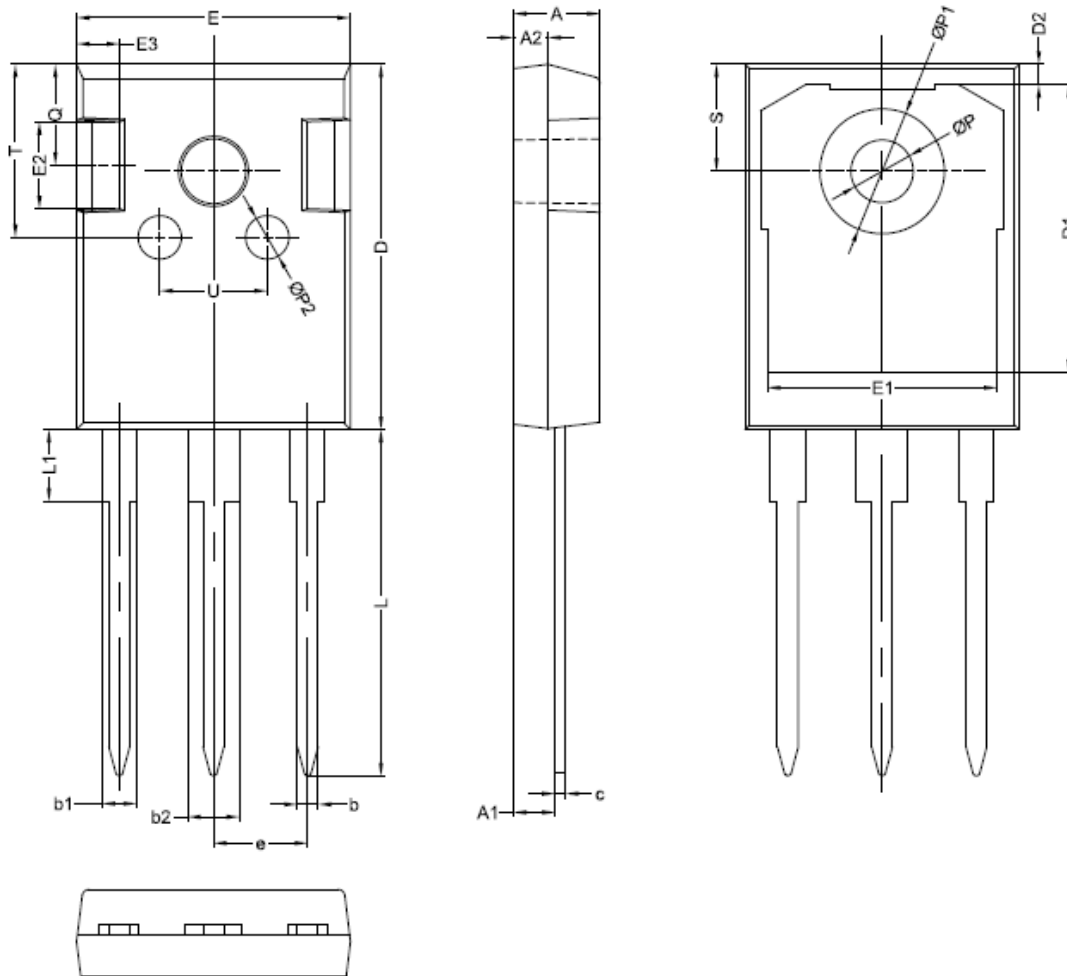

Symbol	Dimensions(mm)		
	Min.	Typ.	Max.
A	4.30	4.70	4.90
A1	2.34	2.54	2.90
A2	-	0.70	-
A3	2.56	2.76	2.96
b	0.55	-	0.95
b1	-	1.28	-
c	0.42	0.50	0.70
D	14.70	-	16.07
D1	-	7.70	-
E	9.96	10.16	10.36
E1	-	8.00	-
e	2.54(BSC)		
H	-	6.70	-
(H1)	-	(0.81)	-
L	12.48	12.98	13.50
L1	-	2.93	-
ΦP1	-	3.18	-
Q	2.90	3.30	3.50

Mechanical Dimensions (Continued)
TO-247
Unit: mm

Symbol	Dimensions(mm)			Symbol	Dimensions(mm)		
	Min.	Typ.	Max.		Min.	Typ.	Max.
A	4.80	5.00	5.20	E2	-	5.00	-
A1	2.21	2.41	2.61	E3	-	2.50	-
A2	1.90	2.00	2.10	e	5.44(BSC)		
b	1.10	1.20	1.35	L	19.42	19.92	20.42
b1	-	2.00	-	L1	-	4.13	-
b2	-	3.00	-	P	3.50	3.60	3.70
c	0.55	0.60	0.75	P1	-	-	7.40
D	20.80	21.00	21.20	P2	-	2.50	-
D1	-	16.55	-	Q	-	5.80	-
D2	-	1.20	-	S	6.05	6.15	6.25
E	15.60	15.80	16.00	T	-	10.00	-
E1	-	13.30	-	U	-	6.20	-



TM

Sanrise Tech**尚阳通**

Sanrise Technology Limited Company

<http://www.sanrise-tech.com>**IMPORTANT NOTICE**

Sanrise Technology Limited Company reserves the right to make changes without further notice to any products or specifications herein. Sanrise Technology Limited Company does not assume any responsibility for use of any its products for any particular purpose, nor does Sanrise Technology Limited Company assume any liability arising out of the application or use of any its products or circuits. Sanrise Technology Limited Company does not convey any license under its patent rights or other rights nor the rights of others.

Main Site:**- Headquarter**

Sanrise Technology Limited Company
Rm.601~603, Building B, SDG Information Port, No.2,
Kefeng Road, Science & Technology Park, Nanshan District,
ShenZhen, P.R.China
Tel: +86-755-22953335
Fax: +86-755-22916878

- Shanghai Office

Sanrise Technology Limited Company
Rm.412, Building 3, No. 1690, Cailun Road,
Zhangjiang Hi-Tech Park, Shanghai, P.R.China
Tel: +86-21-51355061